

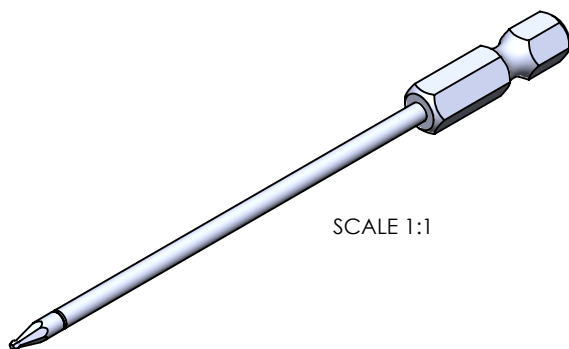

SECTION A-A
SCALE 8 : 1



SCALE 1:1

UNLESS OTHERWISE SPECIFIED: DIMENSIONS ARE IN INCHES				TOLERANCES: X.XX= ±0.13 X.XXX= ±0.015 X.XXXX= -0.0015		 STERITOOL™ The Global Source for Stainless Steel Tools	
DRAWN	NAME	SIGN	DATE				
APPVD	A.T.		01.20.20			TITLE: 1.2MM BALL X 4.00" OAL, 1/4" POWER HEX BIT	
MATERIAL: SHAFT: 465 MAGNETIC S.S. POWER HEX BIT: 316 NON-MAGNETIC S.S.						PART NO. 13082	
THIS DRAWING IS THE PROPERTY OF STERITOOL, INC. ANY REPRODUCTIONS OR MODIFICATIONS OF THIS DRAWING OR ITS CONTENTS WITHOUT THE CONSENT OF STERITOOL, INC. IS PROHIBITED.						SCALE 1.5:1	
						SHEET 1 OF 1	
						REV: A	